

A. ROOF'G, WALL'G & ROOF PLUMB'G.

A.1 INSTALLATION

ALL ROOF AND WALL CLADDING AND ASSOCIATED ACCESSORIES TO BE INSTALLED TO MANUFACTURERS WRITTEN INSTRUCTIONS AND TO RELEVANT AUSTRALIAN STANDARDS.

ROOF AND WALL CLADDING TO BE INSTALLED IN CONTINUOUS LENGTH LONG SHEETS, EXPANSION JOINTS TO BE PLACED AT CENTRES AS RECOMMENDED BY MANUFACTURER.

EXTEND ROOF SHEETS 50MM MINIMUM INTO GUTTERS AND TURN DOWN ENDS OF SHEETS.

ALL ROOF AND WALL SHEETING TO BE SCREWED DOWN INTO FINAL POSITION AS SOON AS POSSIBLE AFTER POSITIONING OF SHEETING, TEMPORARY FIXING OF ROOF SHEETING MUST BE MADE PERMANENT BEFORE END OF DAYS WORK.

A.2 INSULATION, SISALATION AND SAFETY MESH

SUPPLY AND INSTALL AS SPECIFIED INSULATION, SISALATION AND SAFETY MESH OVER MILD STEEL PURLINS PRIOR TO LAYING AND FIXING ROOF OR WALL SHEETS.

SAFETY MESH TO BE FIXED TO RIDGE PURLIN AND PULLED TIGHT IN CONTINUOUS LENGTH FOR FULL SPAN OF ROOF. LAY SISALATION AND/OR INSULATION OVER SAFETY MESH IMMEDIATELY PRIOR TO LAYING ROOF SHEETS.

ENSURE SISALATION/INSULATION IS ADEQUATELY LAPPED WITH ADJACENT SHEETS TO PROVIDE A CONTINUOUS INSULATION BARRIER TO THE FULL EXTENT OF ROOF. ENSURE INSULATION IS CONTINUED UNDER BOX GUTTERS AND FIXED IN POSITION. CHECK ALL INTERNAL EXPOSED SURFACES OF INSULATION FOR CONTINUITY AND MAKE GOOD AS REQUIRED.

WALLS TO OFFICE AREA (INCLUDING EXTERNAL WALLS) ARE TO HAVE A MINIMUM R1.8 VALUE. THE ROOF IS TO ACHIEVE A MINIMUM R3.2 VALUE AND SUSPENDED FLOOR IS TO HAVE A MINIMUM R1.5 VALUE.

A.3 ROOF LIGHTS

INSTALL 760mm WIDE ROOF LIGHTS TO POSITIONS AS INDICATED ON ARCHITECTURAL DRAWINGS, ENSURE ROOF LIGHTS EXTEND TO FULL EXTENT OF ROOF SPAN AND ARE ADEQUATELY FLASHED AT RIDGE, SEAL ALL JOINTS IN ROOF LIGHTS WITH TWO BEADS OF APPROVED SILICON TO PREVENT CAPILLARY ACTION BETWEEN SHEETS.

A.4 RIDGE VENTS

SUPPLY AND INSTALL RIDGE VENTS AS SPECIFIED ON ARCHITECTURAL DRAWINGS COMPLETE WITH BIRD PROOF MESH INSERTS AND STORM BAFFLES. RIDGE VENTS TO MATCH FINISH OF ADJACENT ROOF. ENSURE CLEAR OPENING OF THROAT OF VENT AS SPECIFIED.

A.5 RAINWATER GOODS

INSTALL BOX GUTTERS OR EAVES GUTTERS AS SHOWN ON ARCHITECTURAL DRAWINGS AS SHOWN ON DRAWINGS.

GUTTERS SHALL BE SUPPLIED IN LONG LENGTHS WITH ANY JOINTS TO BE AT THE HIGH POINT OF THE GUTTER, ENSURE ALL JOINTS ARE ADEQUATELY LAPPED AND SEALED TP PREVENT LEAKS.

BOX GUTTERS ARE TO BE SUPPORTED WITH "SPANDEK" ZINCALUME GUTTER BOARDS AND GALVANISED PROPRIETARY GUTTER STRAPS AT CENTRES SUFFICIENT TO SUPPORT GUTTER AND IMPOSED LIVE LOADS.

EAVES GUTTERS TO HAVE GUTTER BRACKETS OF MATCHING MATERIAL 600MM CENTRES.

ALL SILICON ON EXPOSED GUTTERS OR RAINWATER GOODS TO BE PAINTABLE GRADE SILICON.

PROVIDE OVERFLOW POPS OF SUFFICIENT SIZE AND NUMBER TO PREVENT GUTTERS FROM OVERFLOWING IN THE EVENT OF A BLOCKAGE.

A.6 FLASHINGS, CAPPINGS AND FOOTMOULDS

ALL FLASHINGS, CAPPINGS AND FOOTMOULDS TO BE COMPLETED WITH THE ROOF AND WALL CLADDING, ENSURE SUFFICIENT COVER TO ALL SURFACES TO PREVENT THE INGRESS OF WATER, DUST OR VERMIN.

VISIBLE FLASHINGS, CAPPINGS OR FOOTMOULDS TO BE FABRICATED IN MATERIAL MATCHING ADJACENT CLADDING FLASHINGS ETC. TO BE INSTALLED IN CONTINUOUS LONG LENGTHS. ALL JOINTS TO BE LAPPED AND EFFECTED NEATLY.

NON-VISIBLE FLASHINGS ETC. ARE TO BE FABRICATED FROM ZINCALUME SHEETING, SUPPLIED IN CONTINUOUS LONG LENGTHS AND INSTALLED NEATLY.

PROVIDE COLORBOND FOOTMOULDS TO THE BASE OF ALL WALL CLADDING FIXED TO TOP OF PRE-CAST DADO PANELS/EDGE OF FLOOR SLAB. INSTALL FOOTMOULD TRUE AND STRAIGHT, ENSURE FOOTMOULD IS NOT TWISTED DURING INSTALLATION.

A.7 ROOF PENETRATIONS

CUT ROOF PENETRATIONS AND INSTALL UNDERFLASHINGS WHERE DIRECTED OR AS SHOWN ON ARCHITECTURAL AND MECHANICAL DRAWINGS. ENSURE UNDERFLASHING HAS SUFFICIENT UPTURN TO ALLOW OVERFLASHINGS TO BE SECURELY FIXED IN FINAL POSITION.

USE A SUFFICIENCY OF SILICON SEALANT TO ENSURE UNDERFLASHING PROVIDES A WATERPROOF SEAL.

A.8 GENERAL ROOFING NOTES

ROOF DRAINAGE AS PER AS 3500.3.2

ALL DP SIZES AS PER CIVIL DWGS

ALL OVERFLOWS TO BE 150MM DIA UNLESS NOTED OTHERWISE
INTERNAL DP'S TO BE UPVC AND EXTERNAL DP'S TO BE COLORBOND UNLESS NOTED OTHERWISE.

BOX GUTTER EXPANSION JOINTS PROPRIETARY SYSTEM POLYURETHANE RUBBER WITH ZINCALUME COVER PLATES

REFER TO CIVIL DRAWINGS FOR STORM WATER DRAINAGE DESIGN

LEGEND

- DP 150DIA DOWNPIPE
- DP1 150DIA DOWNPIPE CONNECTED TO 250X90X45 SPREADER
- PIT PIT TO CIVIL DETAILS

B. PRE-CAST CONCRETE.

B.1 DESIGN CRITERIA

THE CONTRACTOR SHALL DESIGN AND DETAIL THE PRE-CAST CONCRETE ELEMENTS STRICTLY IN ACCORDANCE WITH THE STRUCTURAL ENGINEER'S DRAWINGS AND TO SIZES AND CONFIGURATIONS AS SHOWN ON THE ARCHITECTURAL DRAWINGS.

B.2 SHOP DETAILS

PRIOR TO FABRICATION OF PRE-CAST ELEMENTS SUBMIT 3 COPIES OF SHOP DETAILS FOR APPROVAL. SHOP DETAILS SHALL BE PREPARED BY A COMPETENT SHOP DETAILER AND SHOW ALL DIMENSIONS AND COMPONENTS OF FINISHED ITEM.

B.3 FORMWORK

FORMWORK FOR CASTING OF PRE-CAST ELEMENTS SHALL BE SMOOTH, FREE OF RUST OR OTHER DELETERIOUS MATERIALS AND PROVIDE A UNIFORM CLASS 2 FINISH TO THE FORMED SURFACES.

B.4 REINFORCED CONCRETE

SUPPLY AND POSITION ALL REINFORCED CONCRETE AS INDICATED ON STRUCTURAL ENGINEER'S DRAWINGS AND APPROVED SHOP DETAILS. ENSURE SUFFICIENT COVER IS MAINTAINED TO REINFORCED CONCRETE AS DETAILED.

B.5 CAST IN ITEMS

CAST IN ALL ITEMS AS SPECIFIED IN POSITIONS AS DIMENSIONED INCLUDING, BUT NOT LIMITED TO, ALL LIFTING INSERTS, TEMPORARY BRACE CONNECTIONS, DOOR AND WINDOW FRAMES, GROUT TUBES AND PENETRATIONS, CAST IN PLATES AND FERRULES.

UNLESS OTHERWISE SPECIFIED ALL CAST IN ITEMS SHALL BE GALVANISED OR HAVE AN APPROVED FINISH PROHIBITIVE TO RUSTING OR STAINING.

B.6 CONCRETE

THE COMPOSITION OF ALL CONCRETE SHALL BE SUCH AS TO PROVIDE THE REQUIRED STRENGTH/GRADE AS INDICATED ON THE ENGINEER'S DRAWINGS.

READY MIXED CONCRETE SHALL COMPLY WITH S.A.A. CODE AS1379-1991 (THE SPECIFICATION AND MANUFACTURE OF CONCRETE)

B.7 FINISHES TO FORMED SURFACES

PROVIDE A CLASS 2 FINISH TO ALL FORMED SURFACES.

B.8 ERECTION/PLACING

PRE-CAST ELEMENTS ARE TO BE ERECTED/PLACED IN ACCORDANCE WITH WORKCOVER VICTORIA SAFE WORK PRACTICES FOR THE ERECTION/PLACING OF PRE-CAST ELEMENTS.

THE CONTRACTOR SHALL ACCURATELY SET OUT ON SITE THE WORKS PRIOR TO PLACING ELEMENTS AND PERFORM ANY PREPARATION WORK REQUIRED THIS INCLUDES BUT IS NOT LIMITED TO DRILLING DOWEL HOLES AND PLACING DOWELS, PLACING PACKING SHIMS, SITE WELDING CONNECTION CLEATS AND PLACING FITMENTS TO ELEMENTS.

PLACE AND FIX ALL TEMPORARY SUPPORTS IN SUCH A MANNER TO HOLD THE ELEMENT IN POSITION SAFELY UNTIL FINAL CONNECTION ARE COMPLETED.

UPON COMPLETION OF ERECTION/PLACING THE CONTRACTOR SHALL CHECK ALL ELEMENTS FOR CORRECT ALIGNMENT AND PLUMBNESS, ADJUST ANY ELEMENTS AS REQUIRED.

B.9 GROUTING/CAULKING

UPON APPROVAL OF FINAL POSITION OF ELEMENTS BY SITE MANAGER THE CONTRACTOR SHALL GROUT ALL ELEMENTS AS NOTED O STRUCTURAL DRAWINGS AND CAULK ALL JOINTS BETWEEN ELEMENTS AS REQUIRED.

B.10 CLEANING DOWN

CLEAN DOWN ALL PRE-CAST ELEMENTS FINALLY, REMOVE ALL MARKS AND BLEMISHES FROM SURFACES OF ELEMENTS.

B.11 PANEL FIRE RATING

CONCRETE PANELS BOUNDING AREAS THAT ARE LOCATED WITHIN 3m OF THE BOUNDARY REQUIRE A 240 / 240 / 240 FIRE RATING. REFER TO ENGINEERS DRAWINGS.

C. PLUMBING

C.1 CONNECT TO EXISTING

CONNECT INTO EXISTING STORMWATER DRAINAGE SYSTEM.

CARRY OUT THE EXCAVATION NECESSARY TO LOCATE AND EXPOSE THE CONNECTION POINT. ON COMPLETION REINSTATE THE SURFACES AND ELEMENTS WHICH HAVE BEEN DISTURBED SUCH AS ROADS, PAVEMENTS, KERBS, FOOTPATHS AND NATURE STRIPS.

UPGRADING TO THE EXISTING DRAINAGE SYSTEM DOWNSTREAM OF THE CONNECTION POINT UNLESS OTHERWISE NOTED IS NOT PART OF THIS CONTRACT.

D. CARPENTRY

D.1 FLOOR, WALL FINISHES

FLOOR, WALL AND CEILING LININGS TO COMPLY WITH CRITICAL RADIANT FLUX AND MATERIAL GROUPING REQUIREMENTS RATHER THAN SPREAD OF FLAME AND SMOKE DEVELOPED INDICES IN ACCORDANCE WITH SPEC. C110a OF THE BCA.

CERAMIC SKIRTING TILE TO UNISEX ACCESSIBLE TOILET FACILITY AND KITCHEN AREA.

WET AREAS ARE TO BE CONSTRUCTED IN ACCORDANCE WITH AS 3740-2004.

D.2 SKIRTINGS

WAREHOUSE -

PRE FINISH MASONITE SKIRTING TO OFFICE AREAS IN WAREHOUSE.

CERAMIC SKIRTING TO WAREHOUSE AMENITIES (INC CLEANERS/INO COVE TILE)

VINYL SKIRTING TO AREA WHERE VINYL FLOORING HAS BEEN LAID UNLESS NOTED OTHERWISE.

OFFICES -

100mm PREFINISHED MASONITE SKIRTING TO OFFICE, LAB & AMENITIES PARTITIONS.

CERAMIC SKIRTING TO OFFICE AMENITIES. (NO COVE TILES)

VINYL SKIRTING TO AREAS THAT HAVE HAD VINYL FLOORING LAID UNLESS NOTED OTHERWISE.

D.2 DOORS

ALL DOORS ARE TO HAVE A MIN DOOR LEAF OF 920mm WITH MINIMUM CLEAR OPENING OF 850mm. ENTRY DOUBLE DOORS MUST EACH BE 920mm LEAFS.

AT ALL EXTERNAL DOORS PROVIDE THRESHOLD HEIGHT OF 190MM MAX.

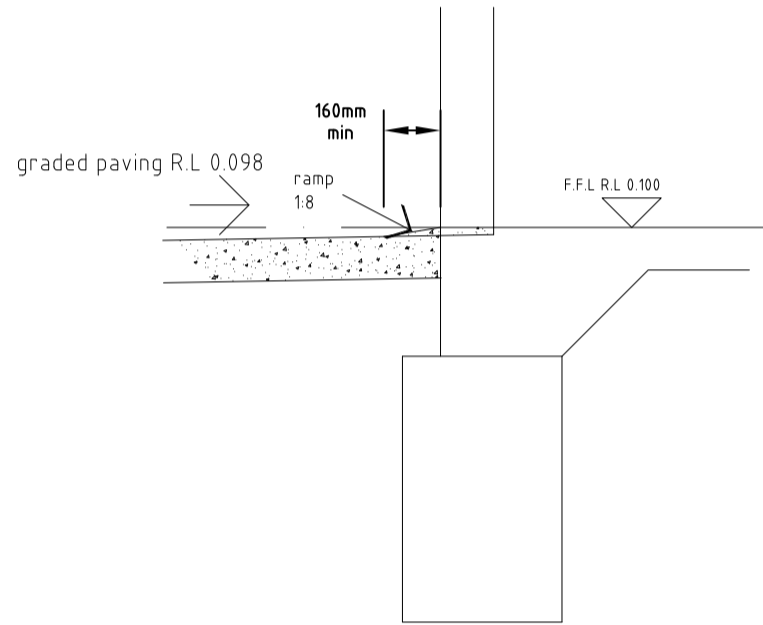

disabled ramp detail

PROVIDE LIFT OFF HINGES TO ALL WC DOORS WHERE DISTANCE BETWEEN PAN & DOOR IS LESS THAN 1.2M (F2.5 OF BCA)

DOORS TO AMENITIES TO UNDER CUT BY 40MM OR PROVIDE DOOR GRILLES FOR VENTILATION.

PROVIDE SELF CLOSERS TO AIRLOCK DOORS OF AMENITIES AND ANY FIRE RATED DOOR. DO NOT PROVIDE SELF CLOSERS TO DISABLED WC.

ALL EXIT DOORS TO BE OPENABLE FROM INSIDE WITHOUT THE USE OF A KEY BY A SINGLE HANDED DOWNWARD MOTION. LATCHING DEVICE TO BE LOCATED BETWEEN 900-1100MM FROM FINISHED FLOOR LEVEL.

ENSURE MINIMUM 110MM HINGE SIDE CLEARANCE IS PROVIDED EXTERNALLY TO THE ENTRY DOOR.

NOTE:-
PROVIDE SITE MEASURE PRIOR TO MANUFACTURE.
ALL GLAZING / POWDER COAT

DOOR TYPES

- METAL CLAD SOLID ESCAPE DOOR, PAINT FINISH
- MDF FACED SEMI SOLID DOOR, PAINT FINISH
- ROLLER SHUTTER DOOR
- ALUMINIUM FRAMED GLAZED DOOR, PC FINISH
- LAMINATED / VINYL CLAD PARTITION DOOR
- AUTOMATIC GLAZED SLIDING DOOR, PC FRAME
- TIMBER SOLID CORE DOOR, PAINT FINISH
- GALV. CHAIN WIRE MESH GATE
- FIRE RATED DOOR TO BCA REQUIREMENTS
- RAPID ROLLER DOOR

ALUMINIUM DOOR HARDWARE

- LOCKSET, LOCKWOOD 590
- CLOSER, DORMA
- HANDLES, DALCO 1231 (CRANKED D PULL)
- FLUSH BOLTS, NOVA NH 75 202-300 BOTTOM
- FLUSH BOLTS, NOVA NH 75 202-450 TOP
- NOVA NH 75 202-300 BOTTOM (CONCEALED IN EDGE OF DOOR)

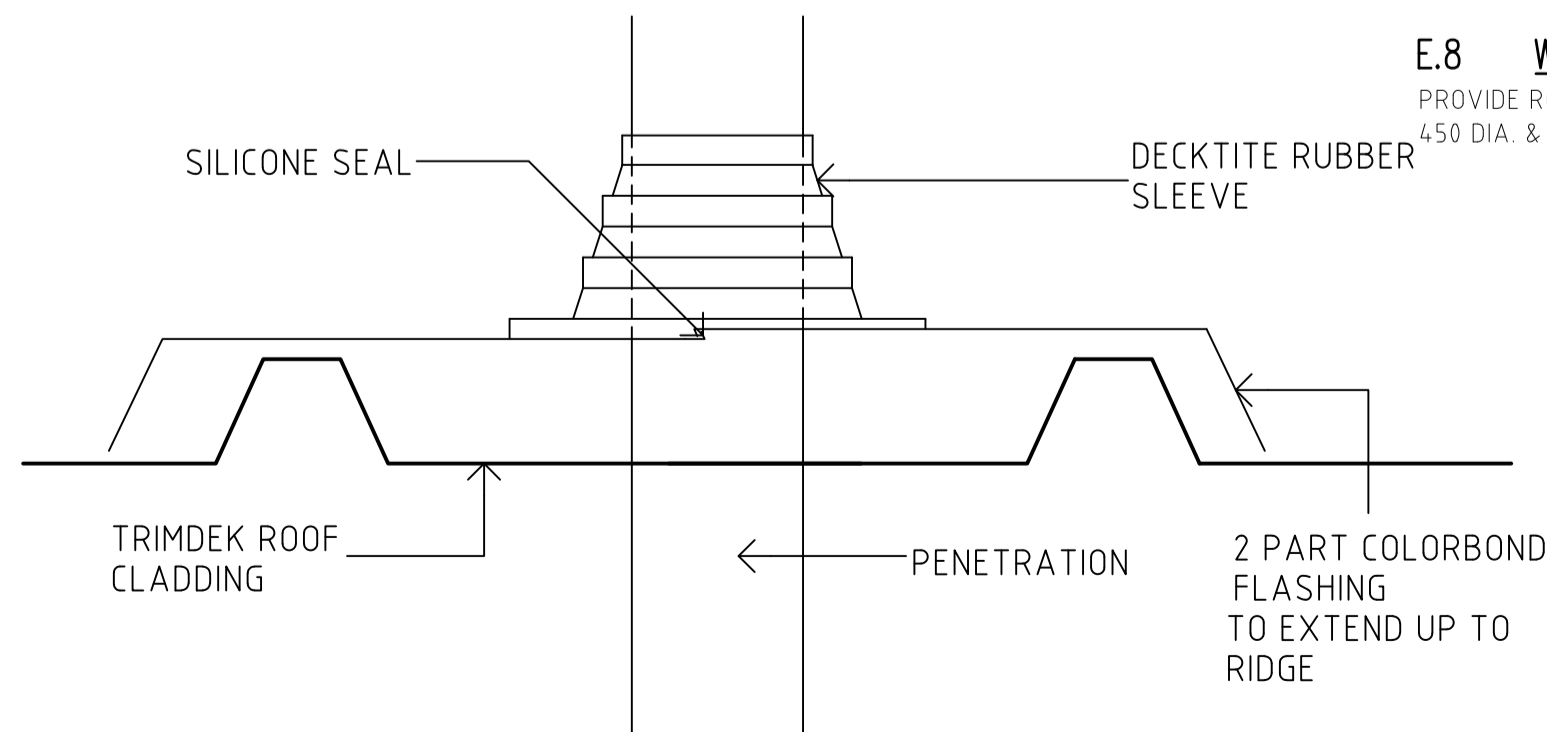

TYPICAL DETAIL
WHERE PENETRATION FALLS
IN ROOF TRAY

FRAME TYPE

- AL-ALUMINIUM POWDER COAT FINISH
- MS/GALV-MILD STEEL GALVANIZED FINISH
- PM-PRESSED METAL
- LS-LOCK SET
- PS-PASSAGE SET
- DC=DOOR CLOSER
- IB=INDICATOR BOLT
- PPP=STAINLESS STEEL PUSH PULL PLATE
- HODC=HOLD OPEN DOOR CLOSER
- DAC=DELAYED ACTION CLOSER
- VP=600Hx300W GLAZED VIEWING PANEL

AUTOMATIC SLIDING DOORS TO OPEN IN THE EVENT OF A POWER FAILURE OR UPON ACTIVATION OF ANY SMOKE OR FIRE ALARM WITHIN THE BUILDING

EXIT DOORS SHOULD BE OPERABLE BY A SINGLE HANDED DOWNWARD ACTION WITHOUT THE USE OF A KEY AT ALL TIMES

PROVIDE DOOR STOP TO ALL OFFICE DOORS
PROVIDE SATIN CHROME LOCKWOOD OR SIMILAR LEVER FURNITURE WITH KEY LOCKING AS REQUIRED TO THE OFFICES
PROVIDE SATIN CHROME ESCAPE LEVERS INTERNALLY AND KEY IN HANDLE EXTERNALLY WITH GUARD PLATE TO WAREHOUSE DOORS INCLUDING RESTRICTING CHAIN TO THE TOP, UNLESS NOTED OTHERWISE.

D. CARPENTRY (CONT.)

SYMBOL LEGEND

- ST=STENCIL CONCRETE
- PC=POLISHED CONCRETE
- COL=COLUMN
- DP=DOWNPIPE
- SV=SHEET VINYL
- VT=VINYL TILES
- CAT=CARPET TILES
- CT=CERAMIC TILES
- CS=CLEANERS SINK
- HWS=HOT WATER SERVICE
- LBT=LAMINATED BENCH TOP
- LV=LAMINATED VANITY
- WHU=WALL HUNG URINAL
- FW=FLOOR WASTE
- DHB=DISABLED HAND BASIN
- WHB=WALL HUNG BASIN
- LC=LAMINATED CUPBOARD
- BWU=BOILING WATER UNIT
- FH=FIRE HYDRANT
- HR=HOSE REEL
- BOL=BOLLARDS
- EJ=BOX GUTTER EXPANSION JOINT
- MR=MIRROR
- SH=SHOWER
- GMFL=GROUND MOUNTED FLOOD LIGHT WITH SECURITY CAGE
- WMFL=WALL MOUNTED FLOOD LIGHT
- BL=BOLLARD LIGHTS
- PMFL=POLE MOUNTED FLOOD LIGHT
- ISPB=DIRECT STICK PLASTERBOARD

INTERNAL WALL TYPES

- WT1=PLASTERBOARD LINED STUD WALLS TO UNDERSIDE OF CEILING
- WT2=WALLS TO EXTEND UP TO UNDERSIDE OF FLOOR OR ROOF OVER P/BOARD LINED.
- WT3=WALLS TO EXTEND UP TO UNDERSIDE OF ROOF TRUSS OR ROOF OVER WITH 50MM ACOUSTIC INSULATION BLANKET, FIRST FLOOR DIVIDING AMENITY WALLS TO EXTEND 300 ABOVE THE CEILING LEVEL WITH AN INSULATION BLANKET TO THE COMPLETE CEILING

WT4=WALLS TO HAVE PLASTERBOARD FIXED ON FURRING CHANNELS TO REINFORCED CONCRETE PANELS WITH 15MM FOILBOARD.

WT5=WALLS TO EXTEND UP TO UNDERSIDE OF ROOF TRUSS OR ROOF OVER WITH 50MM ACOUSTIC INSULATION BLANKET.

WT6=COLOURBOND CLADDING TO BOTH FACES OF WALL. PROVIDE COLOURBOND CAPPING TO TOP.

E. MECHANICAL

E.1 AMENITIES

PROVIDE MECHANICAL VENTILATION IN ACCORDANCE TO AS 1668.2-1991 & PART J OF BCA. VIA CEILING MOUNTED FAN MINIMUM 25 L/S PER CUBICAL DUCTED TO EXTERNAL AIR THROUGH ROOF.

⊗ DENOTE 1X ELECTRIC EXHAUST FAN TO W.C ROOMS. VENTILATION TO DISCHARGE TO OPEN AIR.

PROVIDE DUCTED HEATING AND AIR-CONDITIONING TO OFFICE TO CONFORM WITH THE FOLLOWING DESIGN CRITERIA.

AMBIENT CONDITIONS WILL NOT EXCEED:

SUMMER: 35°C DRY BULB 21°C WET BULB (MAXIMUM)

WINTER: 4°C DRY BULB (MINIMUM)

THE SYSTEMS SHALL BE DESIGNED TO PROVIDE THE FOLLOWING INDOOR CONDITIONS AT THE IMMEDIATE LOCATION OF THE CONTROLLING SENSORS.

SUMMER: 22°C DRY BULB +/- 1.5°C DRY BULB
WINTER: 22°C DRY BULB +/- 1.5°C DRY BULB

ALL GLAZING TO THE OFFICE AREAS TO BE 6MM GREY TINT WITH A SHADING FACTOR OF 0.58, THE ROOF TO THE OFFICE WILL BE INSULATED WITH A MINIMUM OF 50MM PINTICON.

OUTSIDE AIR ALLOWANCES ARE TO BE BASED ON CURRENT REQUIREMENTS AS DETAILED IN AS1668.2

OFFICE AREAS 10 L/S PER PERSON
MEETING ROOMS 15 L/S PER PERSON
LUNCHROOMS 10 L/S PER PERSON

OCCUPANCY LEVELS TO BE BASED ON NCC UNLESS NOTED OTHERWISE.

HEAT GENERATED BY LIGHTING AND MISCELLANEOUS OFFICE EQUIPMENT TO BE ASSUMED AT 20 WATTS PER SQUARE METRE. TO OFFICES & 10 WATTS PER SQUARE METRE TO AMENITIES.

NOISE RATINGS OF EQUAL TO OR LESS THAN 40 NCR.

E.2 PLANT PLATFORMS

CONTRACTOR IS TO PROVIDE TIMBER/ GALVANISED MILD STEEL ROOF MOUNTED PLANT PLATFORMS TO ROOF MOUNTED UNITS, UNLESS NOTED OTHERWISE.

E.3 DUCTWORK, SOLID AND FLEXIBLE

EXTERNAL AIR CONDITIONING DUCTWORK SHALL BE CONSTRUCTED FROM GALVANISED SHEET METAL, COMPLETE WITH INTERNAL ACOUSTIC INSULATION.

INTERNAL AIR CONDITIONING DUCTWORK WITHIN THE CEILING SPACE SHALL BE CONSTRUCTED FROM A COMBINATION OF GALVANISED SHEETMETAL AND FLEXIBLE ALUMINIUM. SHEETMETAL DUCTWORK WILL BE INSULATED EXTERNALLY WITH 25MM THICK INSULATION WRAPPED IN ALUMINIUM FOIL WHILST FLEXIBLE DUCTWORK WILL BE INSULATED WITH 25MM INSULATION WRAPPED IN POLYTHENE.

MECHANICAL VENTILATION DUCTWORK FOR EXHAUST SYSTEMS SHALL BE CONSTRUCTED FROM A COMBINATION OF GALVANISED SHEETMETAL AND FLEXIBLE ALUMINIUM NEITHER REQUIRING INSULATION.

E.4 ROOF FLASHINGS AND PENETRATIONS

THE CONTRACTOR SHALL MAKE ALL ROOF PENETRATIONS FOR DUCTWORK, REFRIGERANT LINES, WATER SUPPLY LINES OF ANY OTHER SERVICES OR REQUIREMENTS COMPLETE WITH ALL UNDERFLASHINGS AND OVER FLASHINGS TO PROVIDE A COMPLETE WATER PROOF SEAL TO PENETRATIONS, AS SHOWN ON THIS PLAN.

E.5 MAINTENANCE AND WARRANTY

THE CONTRACTOR SHALL PROVIDE MAINTENANCE TO ALL AIR CONDITIONING, HEATING AND MECHANICAL VENTILATION FOR A PERIOD OF 12 MONTHS AFTER PRACTICAL COMPLETION.

THE CONTRACTOR SHALL PREPARE A FURTHER MAINTENANCE AGREEMENT FOR USE BY THE CLIENT AND SUBMIT TO THE PROJECT MANAGER UPON COMPLETION.

THE CONTRACTOR SHALL NAME THE CLIENT AS THE INTERESTED PARTY IN THE WARRANTY.

E.6 BCA COMPLIANCE

THE CONTRACTOR SHALL UPON COMPLETION OF ALL WORKS PROVIDE A WRITTEN CERTIFICATION THAT ALL WORKS CONFORMS TO THE AUSTRALIAN STANDARD AND RELEVANT SECTIONS NOT THE BCA, SUBMIT THIS CERTIFICATION TO THE PROJECT MANAGER WITHIN 5 WORKING DAYS OF COMPLETION OF WORK OR EARLIER IF REQUESTED.

E.7 OFFICE

MECHANICAL VENTILATION TO BE PROVIDED TO OFFICE AREAS IN ACCORDANCE WITH BUILDING REGULATIONS AS1668.2 & PART J OF THE BCA VIA SELECTED A/C UNITS MOUNTED ON ROOF OR WALL. REFER TO MECHANICAL DRAWINGS FOR DETAILS.

E.8 WAREHOUSE / FACTORY

PROVIDE ROTAPLEX ROTARY ROOF OUTLET VENTILATOR WITH A FLUE OF 450 DIA. & CAPACITY OF 150 L/S OR AS OTHERWISE NOTED.

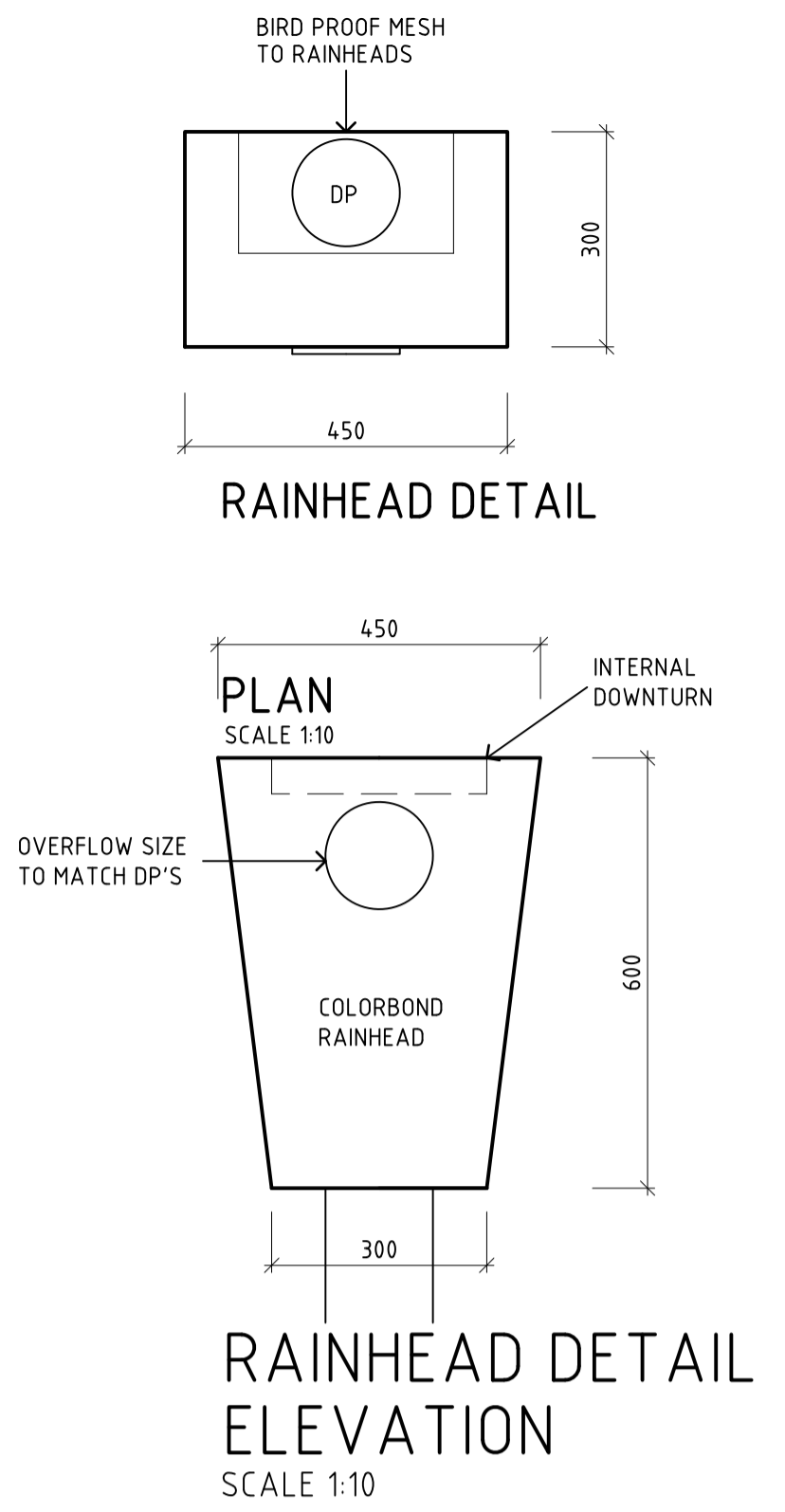

Amendments			
Rev.	By	Date	Description

- ISSUED
- PRELIMINARY
- TOWN PLANNING
- BUILDING PERMIT
- CONSTRUCTION

DRAWING GENERAL NOTES

PROPOSED DEVELOPMENT AT:- 4 Brooke Court, MELTON

CLIENT	
-	-
REVISION	NORTH POINT

DATE	September 2018	SHEET No.	A00
DRAWN	RB	CHECKED	RB
SCALE	AS LISTED	JOB No.	041-2017 WD

© COPYRIGHT

All rights reserved. These drawings remain the property of C.A.D.D.C.O. and is only to be used for its commissioned purpose. No part of this document may be reproduced modified or transmitted in any form or by any means without the explicit written authority of C.A.D.D.C.O. Unauthorized use of this document in any form whatsoever is prohibited.

A1 SHEET

F. OTHER

F.1 STAIRS

ALL STAIRS ARE TO COMPLY WITH AS1428 PART 1. TACTILE INDICATORS ARE TO BE TYPE 'B' INDICATORS AND BE A MIN. 300MM FROM THE STAIR AND NOT LESS THAN 150MM FROM THE STAIR WITH AS 1428.4.

TREADS:- 250 MIN
RISER:- 190 MAX.
HANDRAIL - 1020MM ABOVE LANDINGS AND 865MM ABOVE NOSING OF TREAD.
BALUSTERS:- MAX 125MM SPACINGS, MIN DISTANCE BETWEEN TREADS OF 125MM.
PROVIDE CLEAR 'STICK ON' 3M PRODUCT NON SKID STRIP NEAR EDGE OF NOSING OR AS OTHERWISE NOTED.

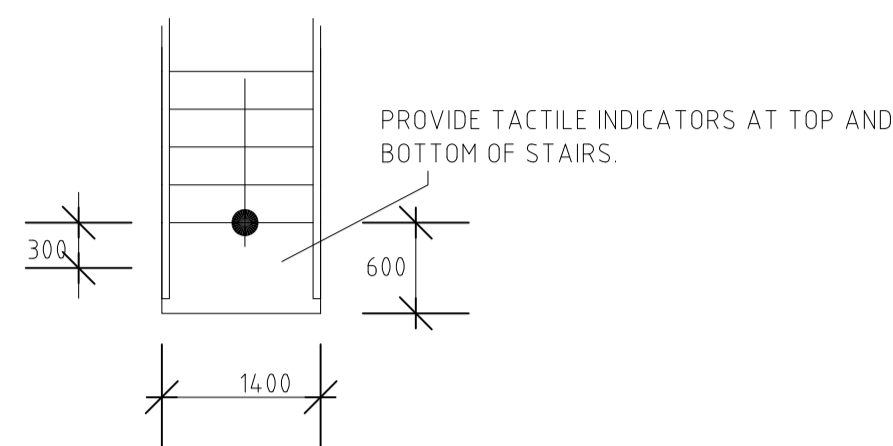

F.2 SANITARY SIGNAGE

EVERY SANITARY FACILITY MUST HAVE CLEAR AND LEGIBLE BRAILLE AND TACTILE SIGNAGE COMPLYING WITH SPECIFICATION D3.6 OF BCA AND AS1428.1. THE SIGNS NEED TO BE LOCATED ON THE LATCH SIDE OF THE TOILET DOORS (LEADING EDGE OF SIGN TO BE BETWEEN 50MM TO 300MM FROM THE ARCHITRAVE) AND THIS NEEDS TO BE LOCATED BETWEEN 1200 & 1600MM AFFL.

F.3 FIRE DOOR SIGNAGE

SIGNAGE TO ALL FIRE DOORS - "FIRE DOOR. DO NOT OBSTRUCT. DO NOT KEEP OPEN". ALL SIGNAGE TO BE IN CAPITAL 20MM LETTERING

F.4 LANDSCAPE

LANDSCAPE SHOWN AS INDICATIVE ONLY. REFER TO LANDSCAPE DRAWINGS BY OTHERS.

F.5 CARPARKING SYMBOLS AND SIGNAGE

PARKING TO INCLUDE THE INTERNATIONAL SYMBOL FOR PEOPLE WITH DISABILITIES IN WHITE ON A GREEN (ULTRAMAYNE) BACKGROUND ON THE BAYS SURFACE AND TOTAL PARKING PERIMETER DELINEATED IN GREEN.

PROVIDE WHITE BITUMENOUS PAINT 75mm WIDE LINEMARKING TO ALL CAR SPACES AND BLUE LINEMARKING TO DISABLED AND DIRECTIONAL LINEMARKING AS REQUIRED

DISABLED CARPARKING SPACES TO BE 3600 X 4900

F.6 DISABILITY ACCESS

ACCESS FOR DISABLED MUST BE PROVIDED BY MEANS OF A CONTINUOUS PATH OF TRAVEL IN ACCORDANCE WITH AS1428.1-2009. MAX PATH SLOPE OF 1:4.0 OR AS OTHERWISE NOTED.

F.7 GLAZING

ALL GLAZING TO COMPLY TO AS1288-2006. USE 125X50 COMMERCIAL CONCRETE ALUMINIUM FRAMED SECTIONS. GLASS TO BE SUPPORTED AT ALL EDGES. FOR DOORS AND SIDE PANELS USE 6MM TOUGHENED SAFETY GLASS. MAX PANEL 4 SQM. ELSEWHERE USE 6MM ORDINARY ANNEALED GLASS. MAX PANEL OF 3 SQM.

F.7 INSULATION

PROVIDE TONTINE INSULWRAP SUPPRESSOR OR SIMILAR TO ALL PVC DOWNPIPES AND ALL WATER AND SEWER PIPES THAT ARE BACKING ONTO OR IN THE OFFICES

F.8 SUSPENDED CEILING

SUSPENSION SYSTEMS SHALL BE CAPABLE OF SUPPORTING THE CEILING AS A WHOLE, TOGETHER WITH LIGHT FITTINGS AND CIREINFORCED CONCRETE LINES.
SUSPENSION SYSTEMS SHALL CONSIST OF SUSPENSION HANGERS SUPPORTING A GRID OF PRIMARY AND SECONDARY MEMBERS.

ALL VISIBLE PARTS OF THE SUSPENSION SYSTEMS SHALL BE PRE-FINISHED TO MATCH THE SUSPENSION SYSTEM.

ALL WALL ANGLES TO BE SHADOW LINE TYPICAL.

F.9 ENTRY DOOR MAT

BIRRUS ULTRA MAT OR SIMILAR CONSTRUCTED FROM NATURAL ALUMINIUM TREAD, RAILS LIGHTLY FURROWED ON THE EXPOSED SURFACE TO PROVIDE A NON-SKID SURFACE AND INCLUDE RUBBER SUPPORT CUSHIONS MOUNTED ON BASE OF EACH TREAD TO COUNTER ANY MINOR SURFACE IMPERFECTIONS

F.10 BOLLARDS

BOLLARDS TO BE USED IN FRONT OF ROLLER DOORS OR WHERE INDICATED ON PLAN ARE TO BE 150 DIA. X 1500MM HIGH CONCRETE FILLED DOME TOP.



G. FIRE SERVICES / HYDRAULICS

G.1 EXTINGUISHERS

EACH EXTINGUISHER TO BE HUNG ON A SUITABLE HOOK. PROVIDE 2A 40 B (E) DRYCHEMICAL LOCATED 1500MM FROM ELEC. SWITCHBOARD.

WAREHOUSE - SUPPLY AND INSTALL EXTINGUISHERS AS REQUIRED IN WAREHOUSE.

STAFF AMENITIES - SUPPLY HAND HELD DRY CHEMICAL FIRE EXTINGUISHERS AS REQUIRED.

1 NO HAND 2.5KG DRY CHEMICAL HELD FIRE EXTINGUISHERS ADJACENT SWITCHBOARDS

G.2 FIRE SERVICES SYMBOL LEGEND

2.5KG DRY CHEM EXTINGUISHER

9.0 KG WATER TYPE EXTINGUISHER

HOSE REEL

G.3 FIRE SERVICES REQUIREMENTS

ALL FIRE SERVICE TO COMPLY TO BCA PART E14. TAPPING TO BE CONFIRMED BY FIRE SERVICES ENGINEER.

G.4 HOSE REELS

TO BE EQUIPPED WITH 36M LIVE HOSE INSTALLED AT A HEIGHT BETWEEN 1500-2400MM FROM FFL TO CENTRE OF REEL. 32MM DIA COPPER PIPE TO BE RUN TO SHUT OFF VALVE AT HOSEREEL.

H. ELECTRICAL

H.1 ARTIFICIAL LIGHTING

ARTIFICIAL LIGHTING TO COMPLY WITH AS 1680 AND ENERGY EFFICIENCY REQUIREMENTS OF PART 'J' OF THE BCA.

H.2 EMERGENCY LIGHTING

EMERGENCY LIGHTING TO BE AS PER ELECTRICAL ENGINEERS DRAWINGS.

H.2 SWITCH BOARDS

REFER TO ELECTRICAL ENGINEERS DRAWINGS FOR ALL MSB AND DB LOCATIONS AND REQUIREMENTS.

LIGHTING LEGEND

SYMBOL	DESCRIPTION
	FACTORY/WAREHOUSE
	ILLUMINATED EXIT SIGN CLEVERTRONICS MODEL EX5410E 'S' SERIES SURFACE MOUNTED 2700 AFL
	OFFICE ILLUMINATED EXIT SIGN CLEVERTRONICS MODEL EX5410E 'S' SERIES SURFACE MOUNTED 2700 AFL
	DIRECTIONAL EXIT SIGN EQUIVALENT TO SUIT EXIT SIGN MODEL IN THE AREA
	2X36 W RECESSED FLUORO FITTING WITH K 12 DIFFUSERS
	3 COMPARTMENT SKIRTING DUCT
	BUILDING MOUNTED FLOOD LIGHT
	GROUND MOUNTED FLOOD LIGHT
	WALL MOUNTED DOCK FLOOD LIGHT
	FACTORY/WAREHOUSE CLEVERTRONICS EMERGENCY LIGHT FITTING CLV 8170 Co-080 C90-C80 MANTAINED/WEATHERPROOF SPACING HEIGHT 2890/20700 6000 3000/22000 7000 3090/23000 8000 3160/23900 9000
	OFFICE CLEVERTRONICS EMERGENCY LIGHT FITTING CLV 8117/8118 Co-C25 C90-C25 2700 ABOVE THE F.F.L.
	2X36 W SURFACE MOUNTED FLUORO FITTING WITH WIRE GUARD
	60 W RECESSED DOWNLIGHT
	50W LOW VOLTAGE DOWNLIGHT LIGHT FITTINGS WITH SEALED LENSES
	400 W LOW BAY METAL HALIDE LIGHT FITTINGS
	400 W HIGH BAY METAL HALIDE LIGHT FITTINGS
	1 X 18 W WALL MOUNTED WEATHERPROOF FLUORO VANDALIGHT
	1 X 50 W NEBULAR BOLLARD LIGHT
	LIGHT SWITCH
	DOUBLE G.P.O ABOVE BENCH TOP
	DOUBLE G.P.O AT SKIRTING LEVEL
	CEILING GRID SETOUT POINT
	ELECTRIC HAND DRYER

I. SITE SAFETY MEASURES

I.1 METHOD OF WORK/SAFETY

DEMOLITION SHALL BE CARRIED OUT IN ACCORDANCE WITH AS 2601.

EXPLOSIVES SHALL BE USED ONLY AFTER PRIOR APPROVAL FROM PROJECT MANAGER.

AT ALL TIMES THE SAFETY OF WORKERS AND OTHER PERSON OCCUPYING THE SITE SHALL BE OF PARAMOUNT IMPORTANCE. UNSAFE WORK PRACTISES SHALL NOT BE ALLOWED.

I.2 TAKE DOWN AND REMOVE

WHERE REQUIRED TAKE DOWN AND REMOVE CAREFULLY, MATERIALS OR SECTIONS OF BUILDINGS NOMINATED FOR PARTIAL DEMOLITION. ALL CARE TO BE TAKEN TO AVOID DAMAGE TO SECTIONS OF EXISTING BUILDINGS TO REMAIN.

I.3 UNDERGROUND COMPONENTS

WHERE REQUIRED REMOVE ALL FOOTINGS, SERVICES, PITS, WELLS AND OTHER UNDERGROUND COMPONENTS OF THE BUILDING, EXCAVATE THE COMPONENT AND BACKFILL WITH APPROVED MATERIAL.

I.4 RECOVERED MATERIALS

UNLESS OTHERWISE NOTED ALL RECOVERED MATERIALS FROM THE DEMOLITION REMAIN THE PROPERTY OF ROSSITER CONSTRUCTION.

I.5 TEMPORARY WEATHERPROOFING

DURING DEMOLITION OR AT SUCH TIMES AS THE CONSTRUCTION PROCESS REQUIRES TEMPORARY WEATHERPROOFING OF THE EXISTING BUILDING SHALL BE CARRIED OUT.

I.6 ASBESTOS REMOVAL

SHOULD ASBESTOS BE ENCOUNTERED THAT HAD NOT BEEN PREVIOUSLY IDENTIFIED, MAKING SAFE OR REMOVING SAME SHALL FORM A VARIATION TO THE CONTRACT. ALL ASBESTOS SHALL BE REMOVED BY AN AUTHORISED AND INSURED CONTRACTOR.

J. EXTERNAL WALL TYPES USED

J.1 - 0.42BMT COLOURBOND TRIMDEK WALL CLADDING (NON VENTED FOOTMOULD) OVER REINFORCED DADO CONCRETE PANEL GIRT INTERNAL WALL SYSTEM AS PER ENGINEERS DETAILS WITH COLOURBOND CLADDING TO OUTERSIDE.

J.2 - 2700 HIGH REINFORCED CONCRETE DADO PANEL AS PER ENGINEERS DETAILS.

J.3 - REINFORCED CONCRETE WALL PANELS AS PER ENGINEERS DETAILS.

J.4 - GLAZED ALUMINIUM AND GLASS FACADE.

K. CIVIL

150MM KERBING TO AREAS SHOWN ON PLAN, UNLESS NOTED OTHERWISE.

REFER TO CIVIL ENGINEERS DRAWINGS FOR ALL DETAILS.

Level	Area	Description	Area
Ground	Warehouse 1 - (gross floor area)		212.82 sqm
	- (showroom area)		52.08 sqm
	- (less stair area)		10.30 sqm
	- (less loading area)		27.36 sqm
	- (net floor area)		227.25 sqm
Mezzanine	Warehouse 1 - (gross floor area)		52.08 sqm
	- (less stair area)		10.30 sqm
	- (net floor area)		41.78 sqm

Level	Area	Description	Area
Ground	Warehouse 2 - (gross floor area)		268.52 sqm
	- (showroom area)		46.77 sqm
	- (less stair area)		10.30 sqm
	- (less loading area)		27.36 sqm
	- (net floor area)		277.63 sqm
Mezzanine	Warehouse 2 - (gross floor area)		46.77 sqm
	- (less stair area)		10.30 sqm
	- (net floor area)		36.47 sqm

Level	Area	Description	Area
Ground	Warehouse 3 - (gross floor area)		314.53 sqm
	- (showroom area)		51.78 sqm
	- (less stair area)		10.30 sqm
	- (less loading area)		27.36 sqm
	- (net floor area)		328.65 sqm
Mezzanine	Warehouse 3 - (gross floor area)		51.78 sqm
	- (less stair area)		10.30 sqm
	- (net floor area)		41.48 sqm

Level	Area	Description	Area
Ground	Warehouse 4 - (gross floor area)		287.96 sqm
	- (showroom area)		32.19 sqm
	- (less stair area)		10.30 sqm
	- (less loading area)		27.36 sqm
	- (net floor area)		282.49 sqm
Mezzanine	Warehouse 4 - (gross floor area)		32.19 sqm
	- (less stair area)		10.30 sqm
	- (net floor area)		21.89 sqm

NOTE: PROPOSED BUILDING AND EXTERNAL CAR PARK AREA TO BE PROVIDED WITH ADEQUATE SECURITY LIGHTING AS REQUIRED, TO BE BAFFLED SO AS THAT NO GLARE WILL SPILL BEYOND SITE BOUNDARIES. ALL EXTERNAL PAVING TO BE GRADED TO STORMWATER DRAIN COLLECTION PITS

Site area	2540.00 sq.m
Total Build Footprint Area -	1266.65m
total site cover	49.86%
Net Floor Area -	1257.64 sq.m
cars provided	23
cars required	18 + 8 = 26

NOTE:-
Landscaping shown is indicative only. Refer to landscape drawings for further details.

NOTE:-
Allow external floodlighting for adequate security. All lighting should be located, directed and baffled to limit light spill beyond site boundaries.

NOTE:-
The location of any existing vehicle crossings to be removed and all other assets located within the road reserve, abutting the subject land, which require relocation is to be relocated or modified at the cost of the developer.

NOTE:-
Existing street road name, currently located where proposed vehicle crossing is, will be relocated to the satisfaction of the responsible authority.

LANDSCAPING

Landscaping to be in accordance with the Estate Design Guidelines & to the requirements of local Council. Refer to Landscape consultant's drawings and specifications for full details.

LIGHTING

External lighting must be designed, baffled and located so as to prevent any adverse effect on adjoining land to the satisfaction of the Responsible Authority.

DISABLED ACCESS

Building entrances are in accordance with the Australian Standard 1428-2001 - Design Rule for Access by the Disabled.

CAR PARKING

Disabled car parking spaces to be 4900mm long x 3800mm wide and be in accordance with A.S. 2890.1 (2004). Car parking spaces to be 4900mm long x 2600mm wide and be in accordance with A.S. 2890.1 (2004). All car parking bays to be line marked in 80mm wide white weatherproof paint in accordance with A.S. 2890.1 (2004).

VEHICLE CROSSINGS

All new crossings shall be to the requirements of the relevant Statutory Authority.

LOADING BAYS

All loading bays to be 7600mm long x 3600mm wide and linemarked in accordance with A.S. 2890.1 (2004).

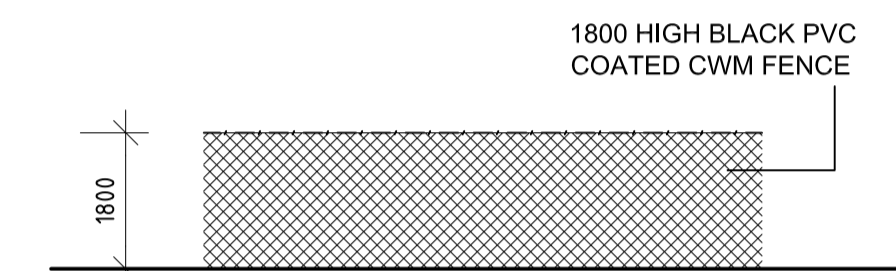

TYPICAL BOUNDARY FENCE ELEVATION
SALE 1:100

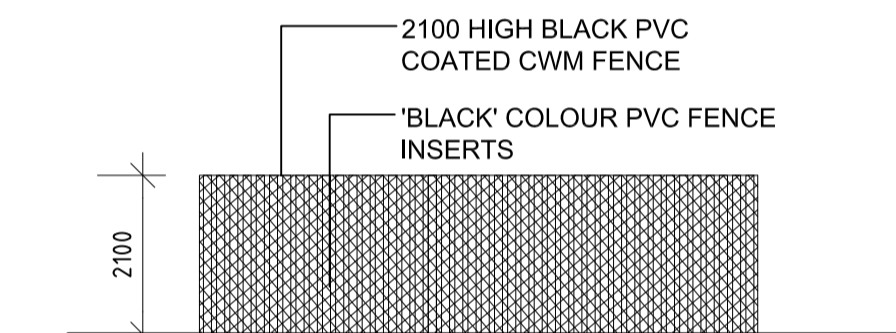

TYPICAL WASTE REFUSE SCREEN FENCE ELEVATION
SALE 1:100

SECURITY EXTERNAL LIGHTING	
	Metal halide low bay flush mounted below awning
	Wall mounted perimeter lighting
	Double luminaire pole mounted at 6m height.

EXISTING TREES	
	Existing trees to remain.
	Existing trees to be removed & relocated.

STREET TREES TO BE PROTECTED IN ACCORDANCE WITH CONDITION 6 OF PLANNING PERMIT.

WASTE STORAGE	
	Location of waste storage bins.

General Notes

1. AREINFORCED CONCRETE structural drawings to be read in conjunction with structural engineer's drawings and computations.

2. All levels relate to Australian datum. Refer to surveyor's drawings.

3. Do not scale drawing, figured dimensions to take preference over scaled sizes.

4. The owner shall be responsible for obtaining all relevant permits and approvals from relevant authorities, including inspections at appropriate stages of construction.

5. Any variations must be approved by the client/ designer prior to proceeding.

6. All Victorian work care - occupational Health and Safety Division codes of practice are to be complied with.

7. Builder must comply with local Authorities municipal by-laws, Victorian Regulations and the Building Code of Australia.

8. All work shall be carried out in a tradesman like manner and comply with relevant codes and to the satisfaction of the relevant building surveyor.

9. Structural framing, fixing, bracing and supports to be in accordance with relevant Australian standards, codes and good Building Practice.



Amendments

Rev.	By	Date	Description

ISSUED

PRELIMINARY TOWN PLANNING
 BUILDING PERMIT CONSTRUCTION

DRAWING

GENERAL NOTES

PROPOSED

PROPOSED DEVELOPMENT AT:- 4 Brooke Court, MELTON

CLIENT

-

REVISION

-

NORTH POINT

-

DATE September 2018 SHEET No. A01

DRAWN RB CHECKED RB

SCALE AS LISTED JOB No. 041-2017 WD

© COPYRIGHT

All rights reserved. These drawings remain the property of C.A.D.D.C.O. and is only to be used for its commissioned purpose. No part of this document may be reproduced modified or transmitted in any form or by any means without the explicit written authority of C.A.D.D.C.O. Unauthorized use of this document in any form whatsoever is prohibited.

A1 SHEET

NOTE:- WALL INSULATION IN OFFICE AREA MUST EXTEND TO THE UNDERSIDE OF THE ROOF OR ALTERNATIVELY CEILING INSULATION IS REQUIRED TO SUSPENDED CEILING. (REFER TO ENERGY REPORT.)

NOTE:- ALL FIRE HAZARD PROPERTIES TO BE IN ACCORDANCE WITH PART C1.10.

NOTE:- ALL WET AREAS ARE TO BE WATERPROOFED IN ACCORDANCE WITH AS3740

NOTE:- ALLOW TO PROVIDE HANDRAIL TO BOTH SIDES OF STAIR IN ACCORDANCE WITH AS1428.1. PROVIDE MIN. STAIR WIDTH BETWEEN HANDRAILS OF 1000MM.

NOTE:- ALLOW TO PROVIDE MECHANICAL EXHAUST SYSTEM TO ALL OFFICE, WC AND KITCHEN AREAS. ALLOW TO DISCHARGE EXHAUST TO OPEN AIR AS PER PART 4.5 OF NCC.

WALL LEGEND

- 1 - 150 THICK PANEL WITH 120/120/120 FIRE RATING
- 2 - 300 THICK PANEL
- 3 - 90MM STUD WALL WITH PLASTERBOARD FINISH.
- 4 - 150MM PANEL WITH METAL FURRING CHANNELS WITH PLASTERBOARD FINISH.(OFFICE)
- 5 - LIGHTWEIGHT STRUCTURE
- 6 - 180MM PANEL WITH METAL FURRING CHANNELS WITH PLASTERBOARD FINISH.(OFFICE)

SECURITY EXTERNAL LIGHTING

- Metal halide low bay flush mounted below awning
- Wall mounted perimeter lighting
- Double luminaire pole mounted at 6m height.

APPROVED
 Permit Number:
BS-L36489/20180238/0
 Issue Date: 16 Mar 2019



GROUND FLOOR PLAN

SCALE : 1 = 100 @ A1 SHEET

A1 SHEET



CADDCO Pty.Ltd.

Architectural Drafting
RAY BUGEJA
 Director

Phone:-03 9191 4391 Mobile:-0411 696 128
 Email:-caddco@bigpond.com
 Postal Address:-P.O. Box 1051 Allona Meadows,3028

Amendments			
Rev.	By	Date	Description

<p>ISSUED</p> <p><input type="checkbox"/> PRELIMINARY</p> <p><input checked="" type="checkbox"/> BUILDING PERMIT</p> <p>DRAWING</p> <p>FLOOR PLAN</p> <p>PROPOSED</p> <p>PROPOSED DEVELOPMENT</p> <p>AT:- 4 Brooke Court, MELTON</p>	<p><input type="checkbox"/> TOWN PLANNING</p> <p><input type="checkbox"/> CONSTRUCTION</p> <p>REVISION</p> <p style="font-size: 2em; font-weight: bold; text-align: center;">A</p> <p>NORTH POINT</p>	<p>10315</p> <p>ELIEN</p> <p>DATE September 2018</p> <p>DRAWN RB</p> <p>SCALE AS LISTED</p> <p>COPYRIGHT</p> <p>SHEET No. A03</p> <p>CHECKED RB</p> <p>JOB No. 041-2017 WD</p> <p>All rights reserved. These drawings remain the property of C.A.D.D.C.O. and is only to be used for its commissioned purpose. No part of this document may be reproduced modified or transmitted in any form or by any means without the explicit written authority of C.A.D.D.C.O. Unauthorised use of this document in any form whatsoever is prohibited.</p>
---	---	--

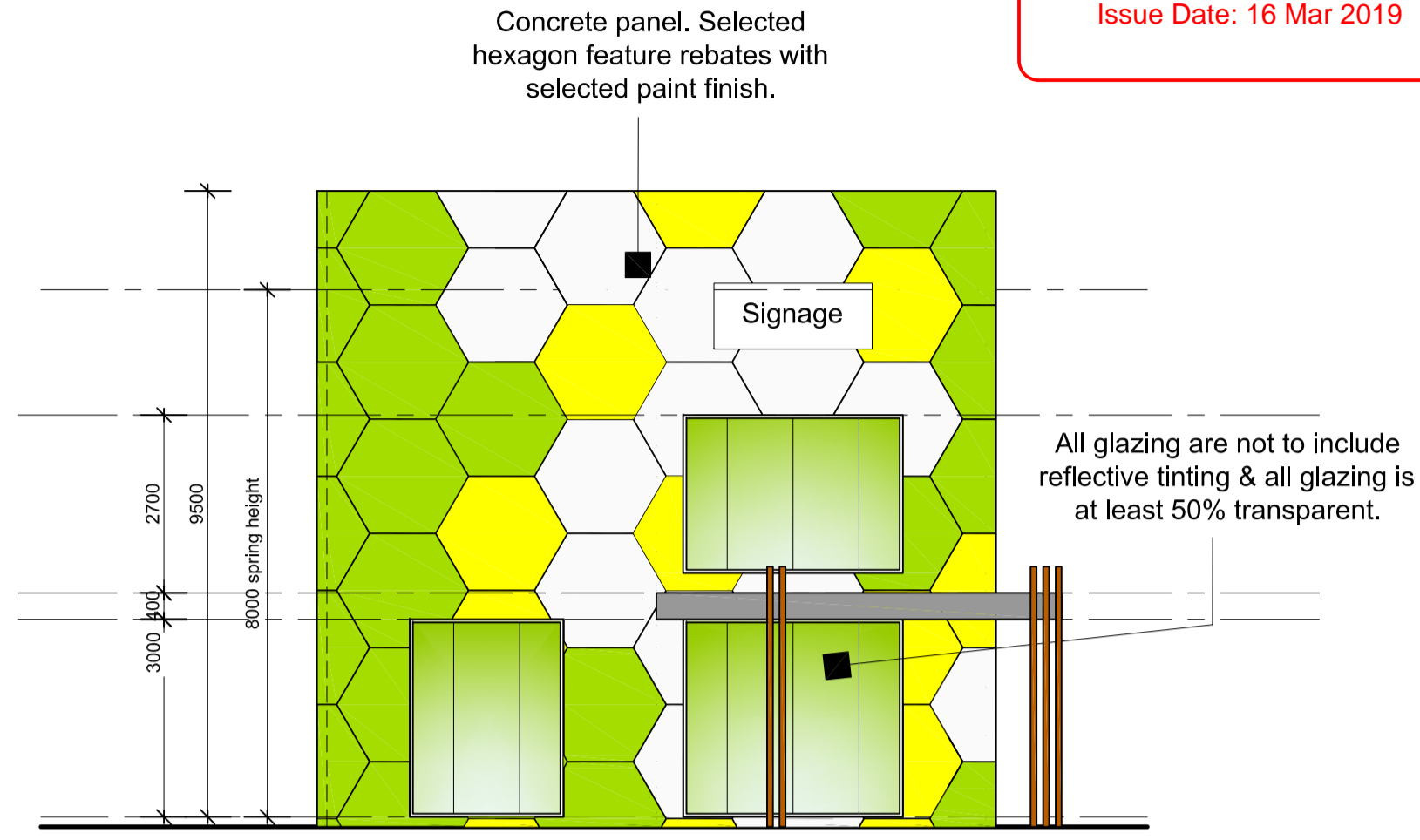

APPROVED
 Permit Number:
 BS-L36489/20180238/0
 Issue Date: 16 Mar 2019

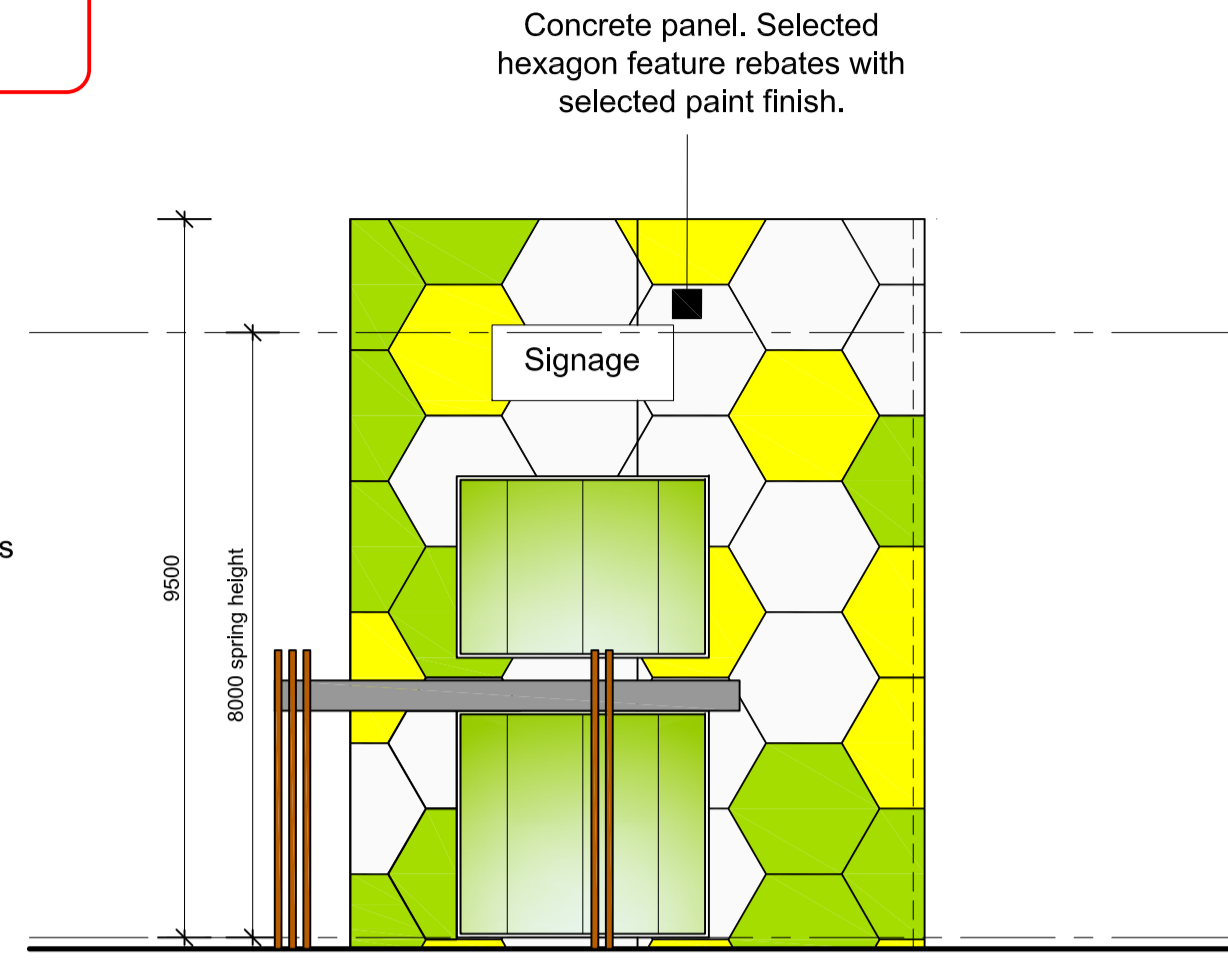

ELEVATION A1
Scale 1 : 100

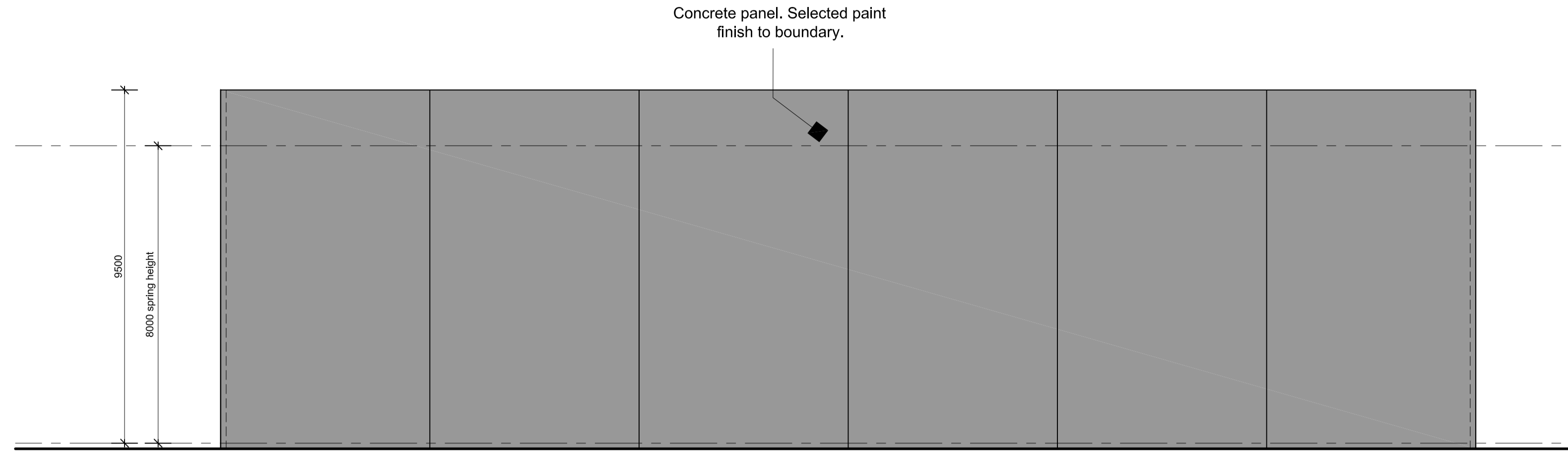

ELEVATION A
Scale 1 : 100



SIDE ELEVATION B
Scale 1 : 100

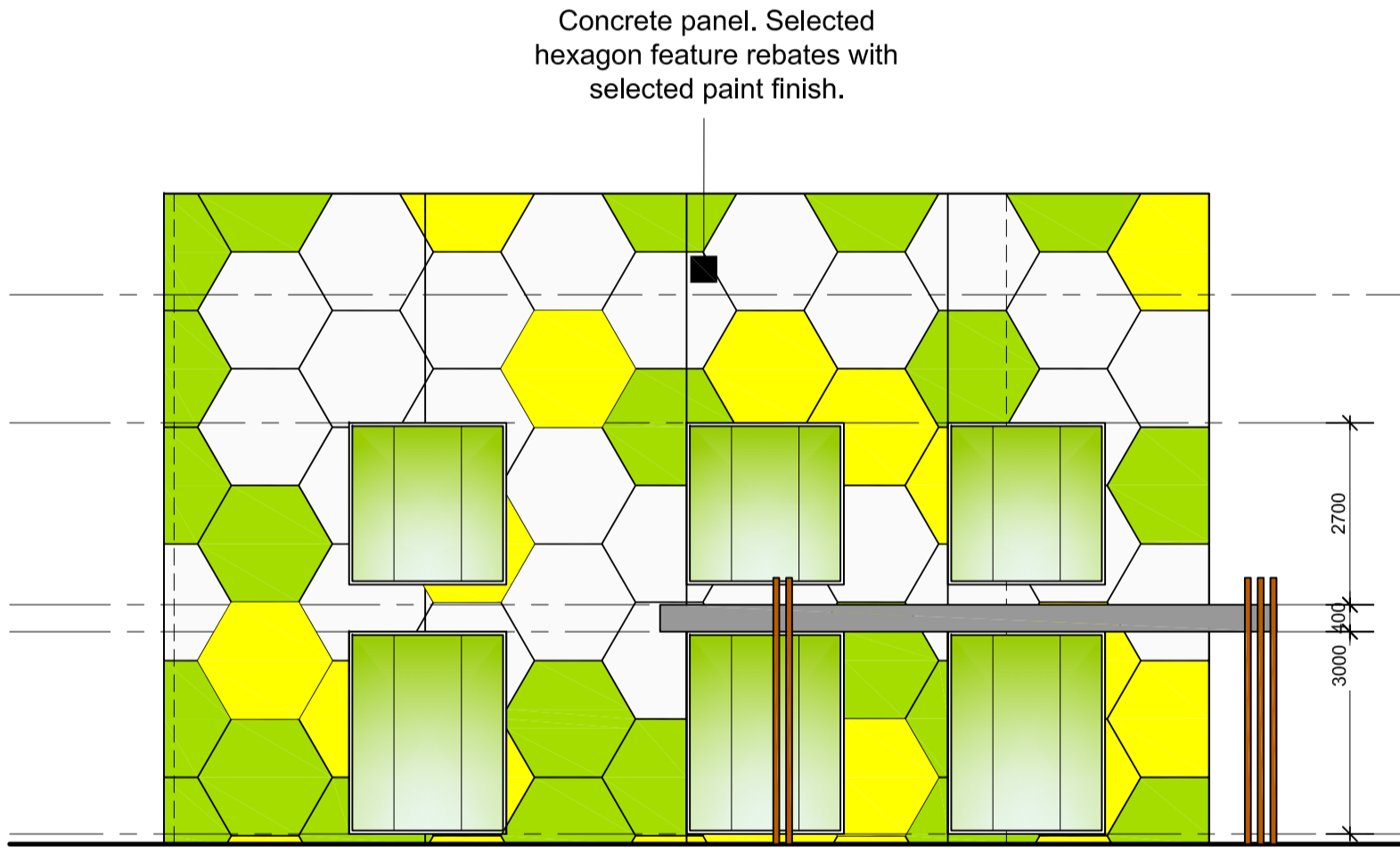

ELEVATION C
Scale 1 : 100

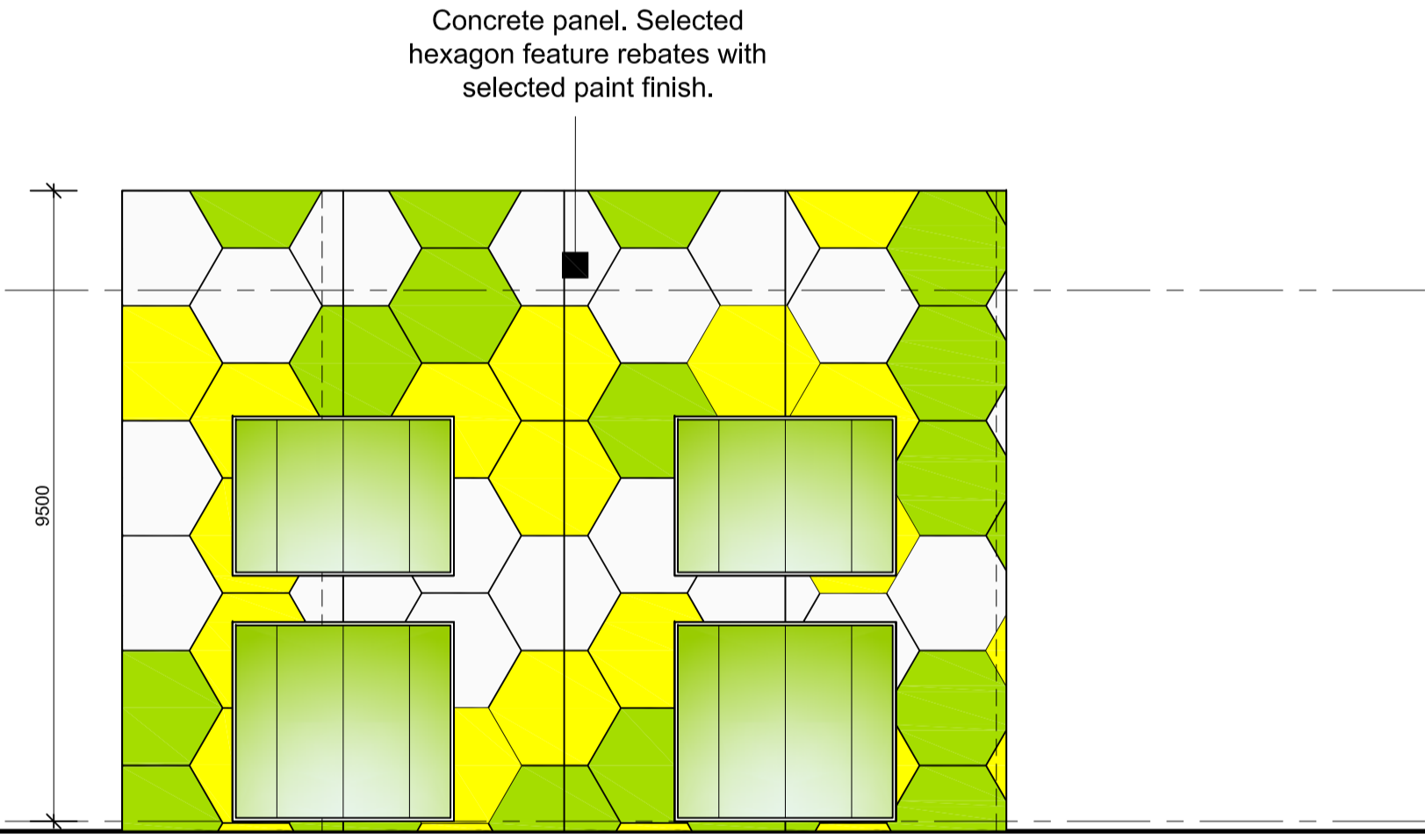

NOTE:-
Allow to provide selected timber retaining wall along boundary with 1.8m high chainwire mesh fencing to sit on top of retaining wall.

NOTE:-
GLAZING TYPE TO BE IN ACCORDANCE WITH PART J ENERGY REPORT.
CLIENT TO CONFIRM COLOUR AND FRAME TYPE.

ELEVATIONS
SCALE : 1 = 100 @ A1 SHEET

A1 SHEET

INTERNAL WALL TYPES

- WT1=PLASTERBOARD LINED STUD WALLS TO UNDERSIDE OF CEILING
- WT2=WALLS TO EXTEND UP TO UNDERSIDE OF FLOOR OR ROOF OVER. P/BOARD LINED.
- WT3=WALLS TO EXTEND UP TO UNDERSIDE OF ROOF TRUSS OR ROOF OVER WITH 50MM ACOUSTIC INSULATION BLANKET, FIRST FLOOR DIVIDING AMENITY WALLS TO EXTEND 300 ABOVE THE CEILING LEVEL WITH AN INSULATION BLANKET TO THE COMPLETE CEILING
- WT4=WALLS TO HAVE PLASTERBOARD FIXED ON FURRING CHANNELS TO REINFORCED CONCRETE PANELS.
- WT5=WALLS TO EXTEND UP TO UNDERSIDE OF ROOF TRUSS OR ROOF OVER WITH 50MM ACOUSTIC INSULATION BLANKET.
- WT6=COLOURBOND CLADDING TO BOTH FACES OF WALL. PROVIDE COLOURBOND CAPPING TO TOP.
- WT7=50MM INSULATION BLANKET TO WALLS



Architectural Drafting
RAY BUGEJA
Director

Phone:-03 9314 0445 Mobile:-0411 696 128
 Email:-caddco@bigpond.com
 Postal Address:-P.O. Box 1051 Allona Meadows,3028

Amendments			
Rev.	By	Date	Description

<p>ISSUED</p> <p><input type="checkbox"/> PRELIMINARY</p> <p><input checked="" type="checkbox"/> BUILDING PERMIT</p>	<p><input type="checkbox"/> TOWN PLANNING</p> <p><input type="checkbox"/> CONSTRUCTION</p>	<p>CLIENT</p> <p style="text-align: center;">-</p>
<p>DRAWING</p> <p>ELEVATIONS</p>		<p>REVISION</p> <p style="text-align: center;">-</p>
<p>PROPOSED</p> <p>PROPOSED DEVELOPMENT AT:- 4 Brooke Court, MELTON</p>		<p>NORTH POINT</p>
<p>DATE September 2018</p> <p>DRAWN RB</p> <p>SCALE AS LISTED</p>		<p>SHEET No. A06</p> <p>CHECKED RB</p> <p>JOB No. 041-2017 WD</p>
<p>© COPYRIGHT</p> <p>All rights reserved. These drawings remain the property of C.A.D.D.C.O. and is only to be used for its commissioned purpose. No part of this document may be reproduced modified or transmitted in any form or by any means without the explicit written authority of C.A.D.D.C.O. Unauthorized use of this document in any form what so ever is prohibited.</p>		

